

5 TANK SEQUENTIAL FILTER (48-85 STAGER)

5 TANK SEQUENTIAL FILTER BACKWASH ONLY

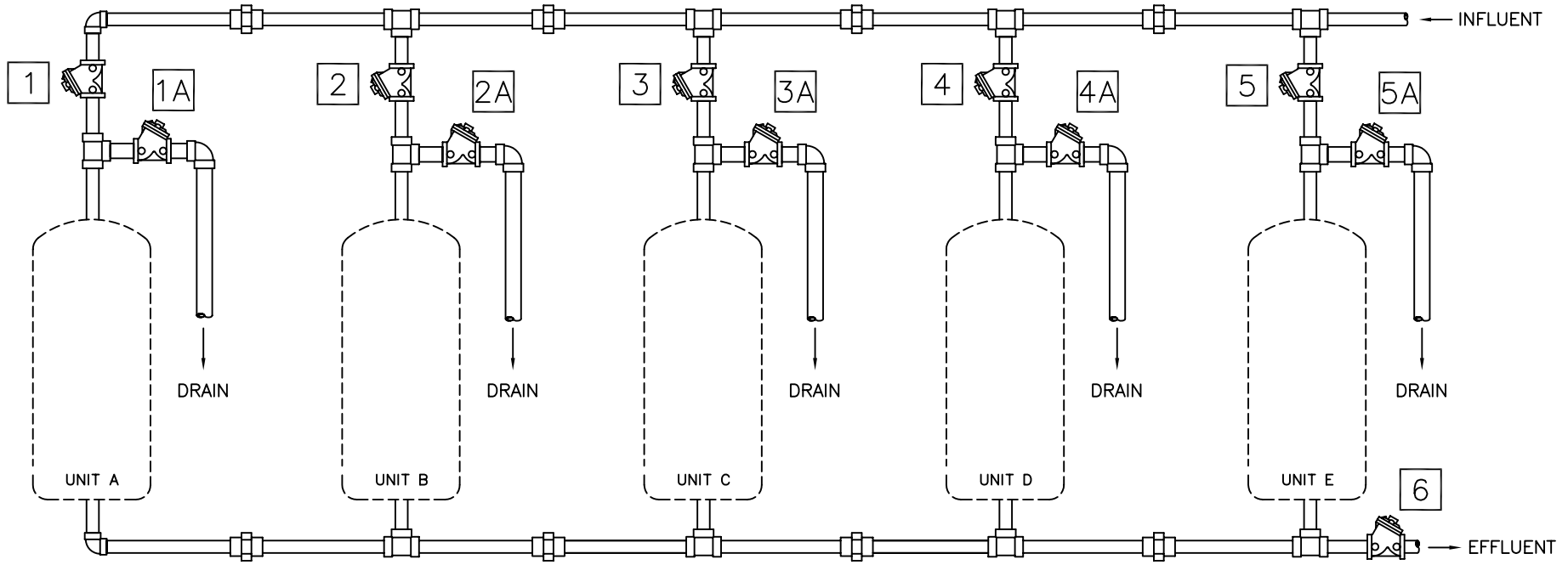

NOTE:

1. ALL OTHER PORTS PRESSURIZED.
2. VALVES 1A,2A,3A,4A,5A,6 ARE NORMALLY OPEN PRESSURE TO CLOSE.
3. VALVES 1,2,3,4,5 ARE NORMALLY CLOSED, PRESSURE TO OPEN.

NOTCH	POS.	FUNCTION	PORTS VENTED (NOTE 1)	VALVES OPEN
A	2	BACKWASH UNIT B	2	1,2A,3,4,5
B	3	BACKWASH UNIT C	3	1,2,3A,4,5
C	4	BACKWASH UNIT D	4	1,2,3,4A,5
D	5	BACKWASH UNIT E	5	1,2,3,4,5A
E	6	SERVICE	6	1,2,3,4,5,6
F	1	BACKWASH UNIT A	1	1A,2,3,4,5

SERIES 48-85 STAGER

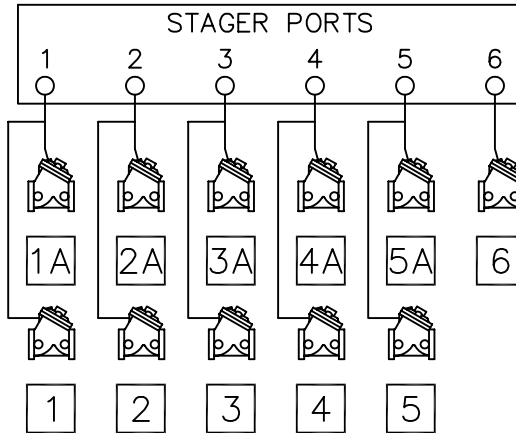

PRINTED IN U.S.A.

A	INITIAL RELEASE	NONE	JWB	31JUL01
REV	DESCRIPTION	ECO	DWN	DATE APVD
<i>AqMatic</i>		16605 West Victor Rd New Berlin, WI 53151 262-326-0100 www.aq-matic.com		
5 TANK SEQUENTIAL FILTER BACKWASH ONLY				
SCALE	DRAWN	DATE	DWG. NO.	
N/A	JWB	31JUL01	1078278	